

simon car seat

USER MANUAL



CE

1 Introduction

Thank you for placing your trust in us and choosing SIMON car seat. We would like to assure you that we have made every effort to make your child's journey in our car seat safe and comfortable. Safety, convenience and ease of use are the values that guided us when designing our car seat.



Before installing the seat in your vehicle for the first time, please read carefully this user manual and the instructions of the vehicle in which the seat will be installed. Following the notes and recommendations given in this manual has a direct impact on the safety of your child in the vehicle.

If you have any doubts concerning the operation of the seat, please contact your dealer or contact us directly:

support@simonseat.com

We wish you a safe journey.

2 Important information and warnings.

SIMON car seat is a restraint device for special needs children with a height of 100 - 150 cm. It is designed for use in "i-Size" category seating positions in accordance with the instructions for use of the respective vehicle. The product has been approved for use in accordance with ECE R129/03. Once the seat has been set up for a child over 135 cm in height, check that the seat fits in the vehicle seat. The i-Size special needs category restraint provides additional support for children who have difficulty maintaining the correct position in

standard seats. Before using the seat for the first time, consult your doctor to make sure the device is suitable for your child.



When installing, take special care that the restraint elements, during normal use, do not become trapped by adjusting the seats or closing the vehicle doors.



Forward-facing restraints should not be used if the child's age is less than 15 months.



The child restraint must not be used if it is not properly secured in the vehicle even for testing purposes.



Seat belts securing the child should be properly tightened, untwisted and adjusted to the child's body.



Seat belts and postural aid elements for the child should fit the child's build and should not be twisted.



If the seat is involved in an accident, the device should be replaced with a new one.



For safety reasons, all luggage and other objects in the vehicle should be secured against accidental movement, as they may cause injury in the event of a collision.



It is forbidden to use the seat without upholstery or to replace upholstery with other than that recommended by the manufacturer.



Making changes to the seat and/or using accessories not approved by the manufacturer may reduce the level of safety offered by the SIMON seat. Such a product must not be used and the manufacturer is not responsible for the consequences of using the device with the changes made and/or accessories used.



Seat elements exposed to sunlight may become hot, which could result in burns to the child's skin. Check the temperature of the seat before use. To protect against heat, cover the seat when not in use.



For safety reasons, do not leave your child unattended in the car seat.

3 Construction of the device

1. Adjustable headrest
2. Insert of the headrest
3. Shoulder belt guide
4. Backrest of the seat
5. Shoulder protector
6. Lateral supports
7. Five-point (stabilizing) belts
8. Seat
9. Side supports
10. Lap belt guides
11. Knee supports
12. Abductor
13. Seat base
14. Seat tilt adjustment handle
15. Seat tilt adjustment button
16. Seat rotation lock release button
17. Locking rod
18. ISOFIX frame
19. ISOFIX connectors
20. Support leg
21. Feet platforms



Fig. 1



Fig. 2

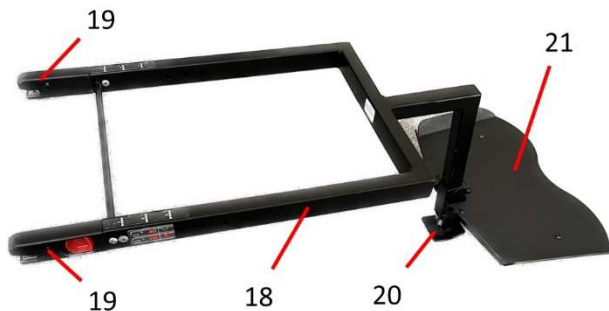

Fig. 3

4 Installation in the vehicle.



The seat can only be installed forward-facing on both front and rear seats equipped with ISOFIX system. It is recommended to install the seat on the rear seat.



SIMON car seat can only be installed on seats equipped with three-point seat belts.



Fig. 4

Make sure that the back of the car seat backrest adheres with its surface to the back of the car seat on which the SIMON seat is installed. If the headrest of the vehicle seat prevents adhesion, the headrest should be removed. Before removing it, check whether the vehicle manufacturer allows it. If not, choose another seat to install the SIMON seat.



Requiring the seat back to adhere to the backrest of the car seat and its tight fitting may cause permanent deformation of the car upholstery. The manufacturer is not responsible for any damage caused by this.



When installing the SIMON seat in the first row of seats, the car seat should be moved as far back as possible.



Before installing the seat in the vehicle, check that there are no sharp elements that could damage the upholstery in the vehicle. The metal construction of the



bottom of the seat can lead to damage of sensitive parts of the vehicle upholstery.

4.1 First, place the ISOFIX frame in the vehicle

Tighten the ISOFIX connectors to the ISOFIX attachment points in the vehicle.



Fig. 5



Make sure the ISOFIX elements are properly fastened and the indicators are green. (Fig. 6)



Fig. 6

- 4.2 Adjust the support leg so that its bottom touches the vehicle floor, see point 7.9



Fig. 7



The support leg of the seat should be adjusted so that it touches the floor of the vehicle.

- 4.3 Attach the SIMON seat to the ISOFIX frame.



Fig. 8

Push the SIMON seat as close as possible to the car seat backrest by selecting position 1, 2 or 3 on the ISOFIX frame (Fig. 9), then insert the locking rod (Fig. 10) and lock the seat position in the selected position (1, 2, 3) by tightening the knob of the bar.



Fig. 9



Fig. 10

5 Seat adjustment

Fitting and adjustment of the SIMON seat can be done outside the vehicle.

1. Adjust seat depth, see point 7.1
2. Place the child in the car seat.
3. Adjust the height of the backrest, see point 7.2
4. Adjust and fit the lateral supports, see point 7.3
5. Adjust and fit the hip supports, see point 7.4
6. Stabilize the child's position with the five-point straps of the SIMON seat, see point 7.5
7. Headrest insert adjustment and adaptation, see point 7.6
8. If necessary, adjust the position of the abductor, see point 7.7

6 Carrying a child

Guide the top of the vehicle's three-point seat belt through the shoulder belt guide. (Fig. 11)



Fig. 11

Guide the bottom of the vehicle's three-point seat belt through the hip belt guide (Fig. 12, Fig. 13.)



Fig. 12



Fig. 13

Fasten the seat belt making sure that the belt is not twisted.



The hip belt should run as low as possible holding the pelvis firmly.

The picture Fig. 14 shows the incorrect routing of the three-point seat belt. The belt must always run through the belt guides



Fig. 14

7 Adjustments:

7.1 Seat depth adjustment (Fig. 15)

To change the length of the seat (1), loosen the locking screws (2) on both sides of the seat with Allen key no. 4

Then grab the front edge of the seat (1) and move the seat to the desired position.

Once the desired seat (1) position is established, tighten the locking screws (2) on both sides of the seat.

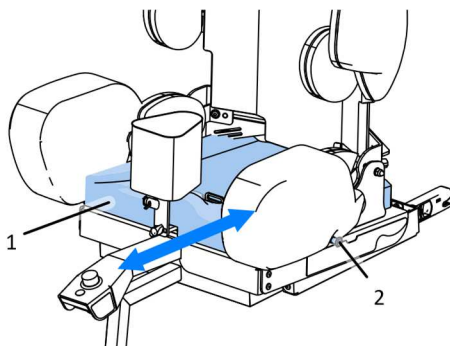

Fig. 15

Together with the seat you have received two seat cushions that differ in length. The shorter cushion is designed for a seat depth range of 30 to 35cm, while the longer cushion is designed for seat depth range of 35 to 40cm.

7.2 Backrest height adjustment (Fig. 16)

Start changing the backrest (1) height adjustment by unzipping the SIMON seat back upholstery.

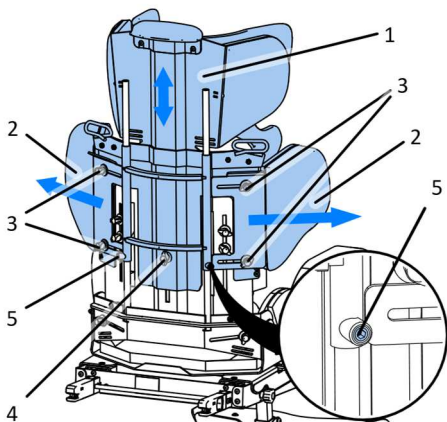

Fig. 16

Loosen the side support (2) adjustment knobs (3), spread the side supports as far as possible and lock them in this position by tightening the knobs (3).

In the next step, loosen the backrest height adjustment knob (4) and loosen the two locking screws (5) with an Allen key no. 4. After determining the desired height, tighten the locking screws (5) and the adjustment knob (4), and fasten the upholstery.

Correct the position of the side supports (2) and adjust them to the space in the vehicle so that they fill the space between the seat and the vehicle door to the maximum. Then tighten the adjustment knobs (3) locking the position of the side supports.

The height of the backrest should be adjusted to ensure that the upper section of the three-point seat belt is correctly positioned as shown in the picture Fig. 17

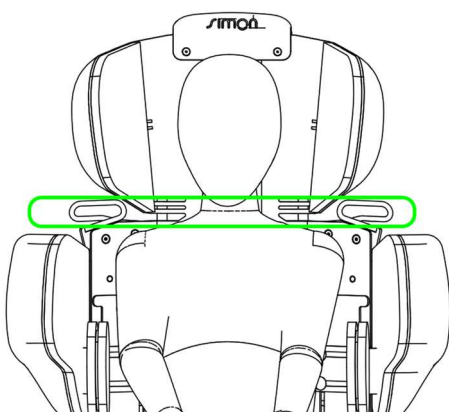

Fig. 17

7.3 Lateral support adjustment Fig. 18

Start adjusting the position of the lateral supports (1) by unzipping the SIMON seat back upholstery and pulling the side supports (2) apart.

Then loosen the two adjustment knobs (3) of the given support. Each support (1) can be adjusted independently, both vertically and horizontally.

After determining the desired position of the support (1), tighten the adjustment knobs(3).

Correct the position of the side supports (2) and adjust them to the space in the vehicle so that they fill the space between the seat and the vehicle door to the maximum. Then tighten the adjustment knobs locking the position of the supports.

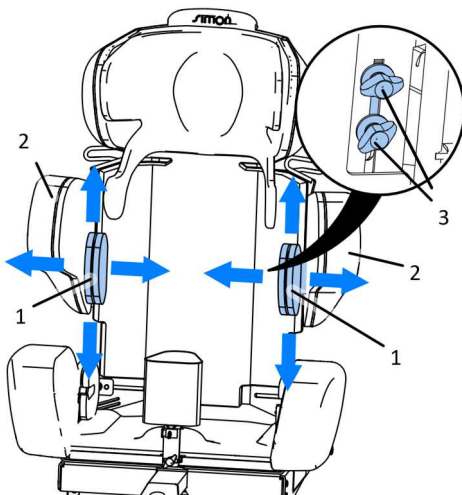

Fig. 18

7.4 Hip supports adjustment Fig. 19

Start adjusting the position of hip supports (1) by unzipping the SIMON seat back upholstery.

Then loosen the adjustment knob (2) of the given support.

The position of each support (1) can be adjusted independently.

After determining the desired spacing of the supports (1), tighten the adjustment knobs.

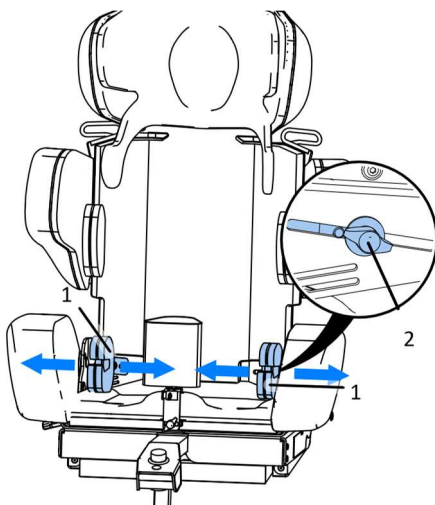

Fig. 19

7.5 Adjustment and operation of five-point straps (fastening-unfastening)

SIMON car seat is equipped with five-point stabilizing belts. They are used to maintain the correct position of the child in the SIMON seat.



Using only the five-point safety belts while driving does not provide sufficient protection in the event of a crash. Always wear a three-point car seat belt.

After placing the child in the seat, place the child's hands under the upper sections of the straps so that the straps run over the shoulders and the adjustment buckles are at the height of the child's chest.



Make sure that the top sections of the belts are not wrapped around the child's neck or rubbing it.

Next, fold the two buckles of the left and right belts together and push them into the central buckle attached to the crotch strap, until the click of the lock is heard Fig. 20. Properly fastening the lock will cause the green colour to appear on the buckle indicator.

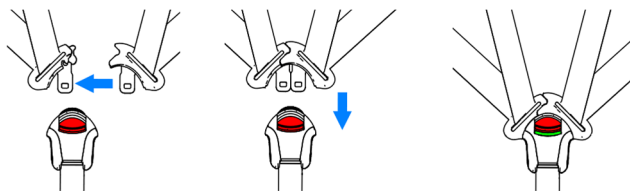

Fig. 20

Once the central buckle is fastened, the tension of the straps can be adjusted by regulating the length of the straps with the adjusting buckles (1) on the child's chest.

By pulling on the belt (2) the tension in the straps is tightened and increased, which stabilises the child's position in the seat. If a change in the position of the adjusting buckle (1) is needed, adjust the length of the belt (3). To relieve the tension in the straps, pull the strap (2) away from the buckle with the button (4) pressed. Fig. 21.

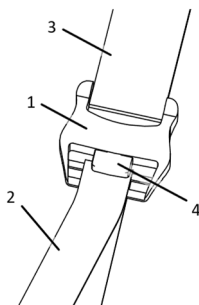

Fig. 21

7.6 Headrest insert adjustment and adaptation Fig. 22

The insert of the headrest can be formed and adjusted according to the child's needs by bending its edges.

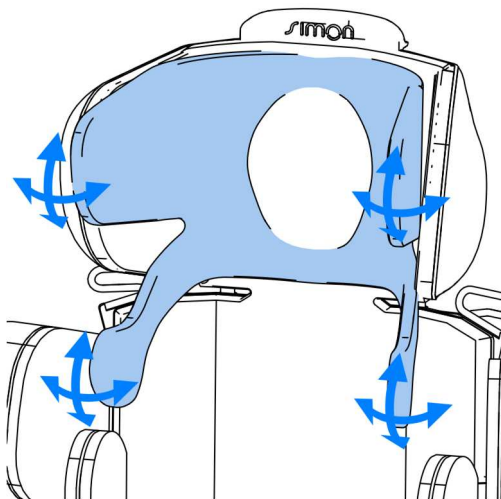

Fig. 22

7.7 Adjusting the position of the abductor Fig. 23

To reposition or remove the abductor (1), loosen the knob (2); this will enable the abductor to be moved along the seat. Once the desired

position of the abductor has been determined, tighten the knob (2) to block the movement of the abductor.

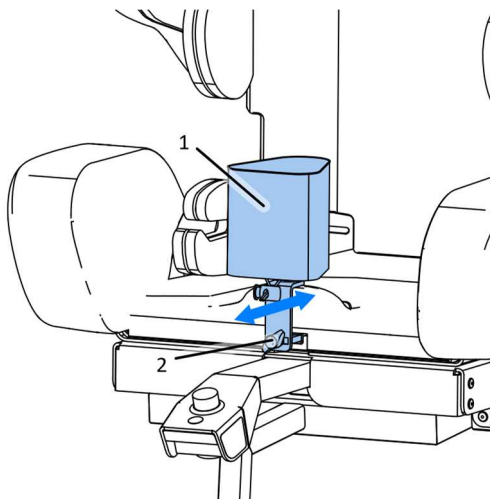

Fig. 23

7.8 Seat tilt angle adjustment Fig. 24

To change the seat tilt angle, grasp the seat tilt adjustment handle (1), press and hold the button (2). By holding down the button (2), it is possible to change the seat tilt angle smoothly. After setting the desired seat position, release the button and the mechanism will automatically lock in the selected position.

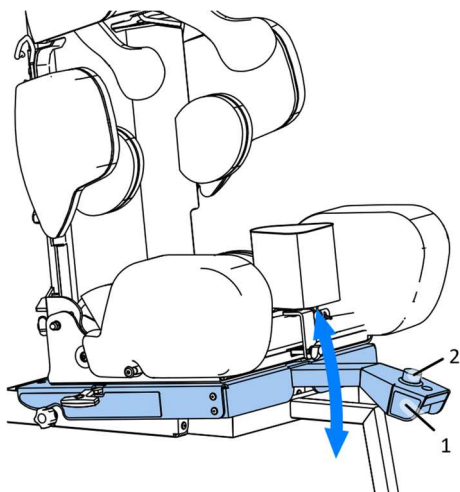

Fig. 24

7.9 Support leg length adjustment Fig. 27

To adjust the length of the support leg (1), unscrew the knob (2) and remove the screw (3). Then extend the profile (1) to the desired length so that the bottom edge of the foot is supported by the floor of the vehicle. Place the screw in the hole (3) and tighten the adjustment knob (2).

7.10 Seat rotation

For more convenient use of the seat, the seat is equipped with a swivel function. To unlock the swivel, pull back the lever(1) and rotate the seat. The swivel function should not be used when the child is fastened with a three-point seat belt. When rotating the seat, make sure that the seat is not in a tilted position - tilt. Rotating the seat to the driving position will automatically retract the lever (1) and lock the seat rotation.

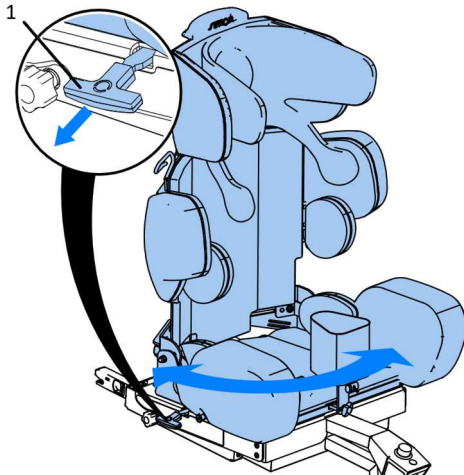

Fig. 25

7.11 Tray

The seat can be equipped with a tray attached with velcro to the upholstery knee support

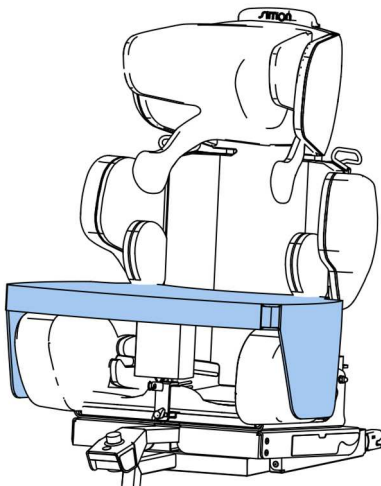

Fig. 26

7.12 Support leg length adjustment Fig. 27

To adjust the length of the support leg (1), unscrew the knob (2) and remove the screw (3).

Then extend the profile (1) to the desired length so that the bottom edge of the foot is supported by the floor of the vehicle.

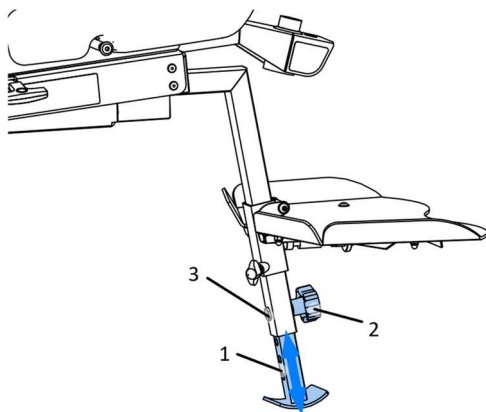

Fig. 27



The support leg of the seat should be adjusted so that it touches the floor of the vehicle.

7.13 Footrest height and angle adjustment Fig. 28

To change the height of the footrest (1), loosen the knob (2). After determining the desired height of the footrest, tighten the knob (2).

To adjust the angle of the footrest (1), use the adjustment knob (3) under the footrest plate.

By turning the adjustment knob (3) clockwise, the angle of the footrest is increased, while by turning the adjustment knob (3) counterclockwise, the angle of the footrest is decreased.

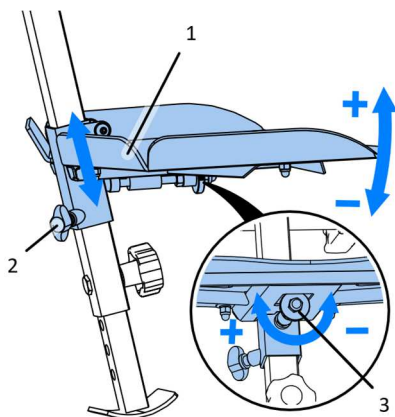

Fig. 28

8 Using the built-in speakers

SIMON car seat is equipped with two built-in speakers located in the headrest.

To connect the player, unzip the upholstery of the SIMON seat back and find the cable ending in a 3.5mm mini jack plug. The plug fits most MP3 players and smartphones equipped with mini jack headphone connector. In case of being equipped with a different type of

headphone connector, it is necessary to use an appropriate adapter (not included in the set).

9 Cleaning and maintenance

The SIMON seat upholstery can be washed in a washing machine at up to 30°C. When spinning, do not exceed 600 rpm.

The foam inserts should be removed from the upholstery before washing.

Other elements of the seat should be cleaned with a damp cloth or sponge. It is permissible to use mild detergents.

Moving parts of the seat do not require periodic maintenance or lubrication.

10 Guarantee

If any faults or damage are noticed, stop using the device immediately and contact your dealer or the manufacturer. A damaged device should be secured to prevent the damage area from expanding. Do not attempt to repair the appliance yourself. Do not replace the original parts of the device with self-made parts or parts from a source other than that recommended by the seat manufacturer. The guarantee does not cover damage caused by daily use, wear and tear of the upholstery elements or deterioration of materials due to aging.



simon

Edition 1 - 2022

SIMON Sp. z o.o.
ul. Pojezierska 97B
91-341 Łódź, POLAND